

# HSAJET® Touch Industrial PC

TIPC15

Flexible printer controller with black anodised aluminium frame and stainless steel casing

## HSAJET® Industrial Touch Printer Controller utilizes HP TIJ 2.5 technology

The Touch Industrial PC builds on the HSAJET® controller board (CB) solution driving reliable HP TIJ2.5 technology.

The built-in controller board is PCI based and can control up to 2" of print height in any combination or orientation of 4 x 1/2" swaths.

## Industrial casing

The black anodised aluminium frame and steel case provide extra protection for harsh industrial environments.

## HSAJET Software

Specially designed software packages drive TIPC15 controllers:

- CODING & MARKING
- GRAPHICS & MAIL
- PHARMACEUTICAL

All HSA software solutions provide the features needed for their respective markets; examples include database connectivity, vision system control and unique serialization capability. All HSA software solutions provide an easy to use, intuitive design.

## Advanced software features

Stitching accuracy down to pixel level means printable objects can be located anywhere on the canvas without limitation.

All TIPC15 software packages offer flexible ink saving feature providing up to a 75% ink saving.

## Remote control

The comprehensive communication protocol allows you to control the unit remotely. Eight outputs allow for integration of the controller into the most complex systems.

Remote management is done through ethernet or serial connection.



## Powerful solution

The availability of different print head styles makes the system usable in a variety of applications printing horizontally or vertically/down.

The combination of hardware and software provides a powerful printing solution as a standalone solution or as part of an integrated application.

## Choose between standard or premium model

A standard model as well as a premium model is available. The standard model is perfect for running CB INKdraw or Mail INKdraw. The premium model is recommended for integrations using a camera solution. For Pharma INKdraw the premium version is always required.

## Print at breakthrough speeds of up to 300 m/min in 300 x 150 dpi

- GRAPHICS
- COUNTERS
- SHIFT CODES
- DATE & TIME
- FIXED TEXT
- LINEAR & 2D BARCODES
- REAL-TIME PRINTING
- VARIABLE TEXT
- ANY WINDOWS TRUE TYPE FONT

# Technical Details

## HSAJET TOUCH INDUSTRIAL PRINTER CONTROLLER TIPC15-HP

### Key features

- 2" PRINT HEIGHT
- PRE-CONFIGURED WINDOWS DRIVEN CONTROLLER
- CREATE AND EDIT JOBS DIRECTLY ON THE TOUCH SCREEN
- SOFTWARE IS AVAILABLE IN MANY LANGUAGES. CONSULT YOUR HSA SALES REPRESENTATIVE FOR A COMPLETE LIST.
- COMPREHENSIVE COMMUNICATION PROTOCOL
- CAN PRINT FULLY VARIABLE INFORMATION
- DATABASE CONNECTIVITY: SQL - TXT - ACCESS, AND MORE
- OPERATOR FRIENDLY SOFTWARE WITH CONFIGURABLE USER INTERFACE
- USER PROMPTS
- OPTIONAL INTEGRATED CAMERA CONTROL

### Accessories:

- SENSOR AND ENCODER
- MOUNTINGS  
(PREP. FOR INOCON FLV-25 / FLV-40 / FLS30-S1)
- KEYBOARD / MOUSE
- STACK LIGHTS / BEACONS
- PRINT HEADS

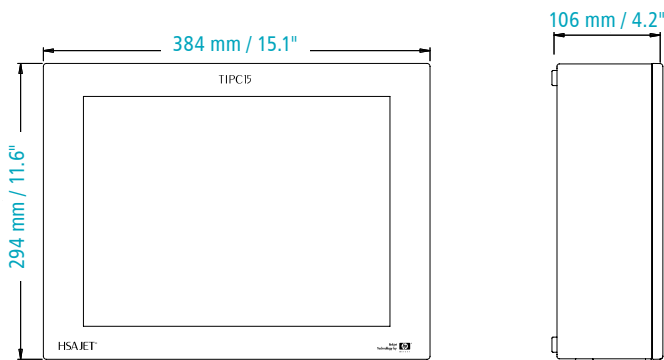

Resolution (DPI) (horizontal x vertical)	Max. speed	
	m / min	feet / min
600 x 600	38	125
600 x 300	76	250
300 x 300	76	250
300 x 300 HS	152	500
300 x 600	38	125
300 x 150	306	1000

### Print capability:

Number of messages: unlimited  
 Message length: max 2700 mm / 106"  
 Print height: max 50.8 mm / 2"

Technology: HP TIJ 2.5  
 Interface: I/O connector  
 Ethernet /Serial  
 Product sensor 5-24V  
 Encoder input 5-24V

TIPC15 PC min. configuration	Standard	Premium
Hard disk	160	160
RAM	1 Gb	2 Gb
Processor	1.5 Ghz	2 Ghz
Printing Software	CB INKdraw Mail INKdraw	CB INKdraw Mail INKdraw Pharma INKdraw
Operating System	Windows XP Pro	

### Technical Data - TIPC15:

Weight: 8.1 kg / 17.8 lbs  
 Voltage: 100 - 240 VAC

CE compliant

Inkjet  
Technology by   
invent

### DEALER:

#### RICO CONSULT

Transportbuen 5, DK - 4700 Næstved  
 Tel. +45 55 53 29 10, Fax + 45 55 53 29 19  
 post@ricoconsult.dk, www.ricoconsult.dk



HSA Systems Denmark  
 DK-2740 SKOVLUUNDE | +45 4494 0222 || DK-5260 ODENSE S | +45 6610 3401

HSA Systems France  
 F-93160 NOISY-LE-GRAND | +33 1 4815 5050  
 www.hsasystems.com | mail@hsasystems.com